

# Crystal CS4328 DAC

(18 bit, Bitstream)

## Obsolete

### Parts Suppliers:

Digi-Key Corporation  
701 Brooks Ave. South  
Thief River Falls, MN 56701

Voice: (800) DIGIKEY  
Voice: (218) 681-6674  
Fax: (218) 681-3380  
<http://www.digikey.com>

Crystal Semiconductor  
PO Box 17847  
4210 S. Industrial Dr.  
Austin TX 78744

Voice: (800) 888-5016  
Voice: (512) 445-7222  
Fax: (512) 445-7581  
<http://www.crystal.com>

## NOTES:

- All parts except the crystal chips can be ordered from Digikey, the Digikey part numbers are listed in the parts list. Crystal Semiconductor has distributors worldwide, call or write to Crystal Semiconductor to find the location of the distributor nearest you.

## BOARD ETCHING TECHNIQUE:

The artwork is printed onto transparency film from a laser printer, print it three times. Cut out two of the prints with about a quarter inch of clear space around the circuit board image. Then carefully tape these two copies to the uncut one after carefully aligning the traces of the overlay to the uncut sheet's traces. When finished, there should be three perfectly stacked copies. This increases the contrast of the final image. When a transparency is printed with a laser printer, there are usually holes in the black printed parts. And the blacks aren't all that black when it is held up to the light. Overlaying makes the blacks much more black, and gets rid of the holes. Now the artwork is ready to use.

This method uses GC<sup>®</sup> positive sensitized boards and developer. The FR-4 fiberglass 1 Oz. grade board works very well (they can be gotten local electronics stores). The board emulsion is sensitive to UV light, A good source of UV to expose the board is a GE<sup>®</sup> sunlamp. The sunlamp is hung so the bottom of the bulb is about 12" above the board. The exposure time is 9 minutes. With a yellow incandescent bug light-bulb on, pull the protective coating off the board and carefully align the artwork on top of the board. Then cover the artwork with a piece of glass to hold the artwork against the board (just like making a contact print in photography). Then turn the sun lamp on for 9 min. If a sunlamp is unavailable, the sun at noontime (on a clear day) can be used exposing the board for about 20 minutes.

The exposed board gets dumped into the developer which has been mixed up beforehand. The developer says to use a 1:9 concentration of developer to water, but a 1:5 mix can be used, which works faster and can yield slightly better results. However the timing is more tricky, so it is not recommended for the first time. Submerge the board into the developer (A photography developer tray works very well), and rock the solution back and forth over the board. The exposed parts will start to dissolve. The emulsion is green and it will wash away exposing the copper underneath. This is the tricky part. The board must be removed when all the emulsion is off the exposed areas. If the board is removed too soon, the emulsion won't be completely dissolved off the exposed areas and it won't etch, if the board is in the developer too long all the emulsion dissolves and all that is left is a bare board. With the 1:9 solution this time window is about a minute, with a 1:5 solution it's about 20 seconds. The board is removed from the developer and washed off with room temperature water, then scrape at an exposed area and see if there is any emulsion left there. If there is, place the board back in the developer for a few seconds. Repeat this as necessary until the exposed areas clear. With a little practice, it's pretty obvious when it's time to pull the board out. Do all the developing using the yellow bug light. When the board is done, wash it off and let it dry. Be careful of the emulsion, it's easily scratched, especially when fresh from the developer.

Next, drop the board into an etching solution. Ferric Chloride is available from the same electronic outlets where the GC<sup>®</sup> boards and developer are purchased or from Radio Shack<sup>®</sup>. Ferric Chloride is a nasty smelling, iodine looking, serious staining stuff. Pour out the developer from the tray, wash it out and add the etchant. Then put the board into the etchant and rock gently back and forth for about a half hour or so, until all the exposed areas are clear. Then remove the board and wash it clean. The emulsion can then be removed with acetone or alcohol.

Then all the holes need to be drilled in the board. A Dremel<sup>®</sup> moto tool works well for drilling the small holes, a small drill press would also work.



SIGNAL SIDE:

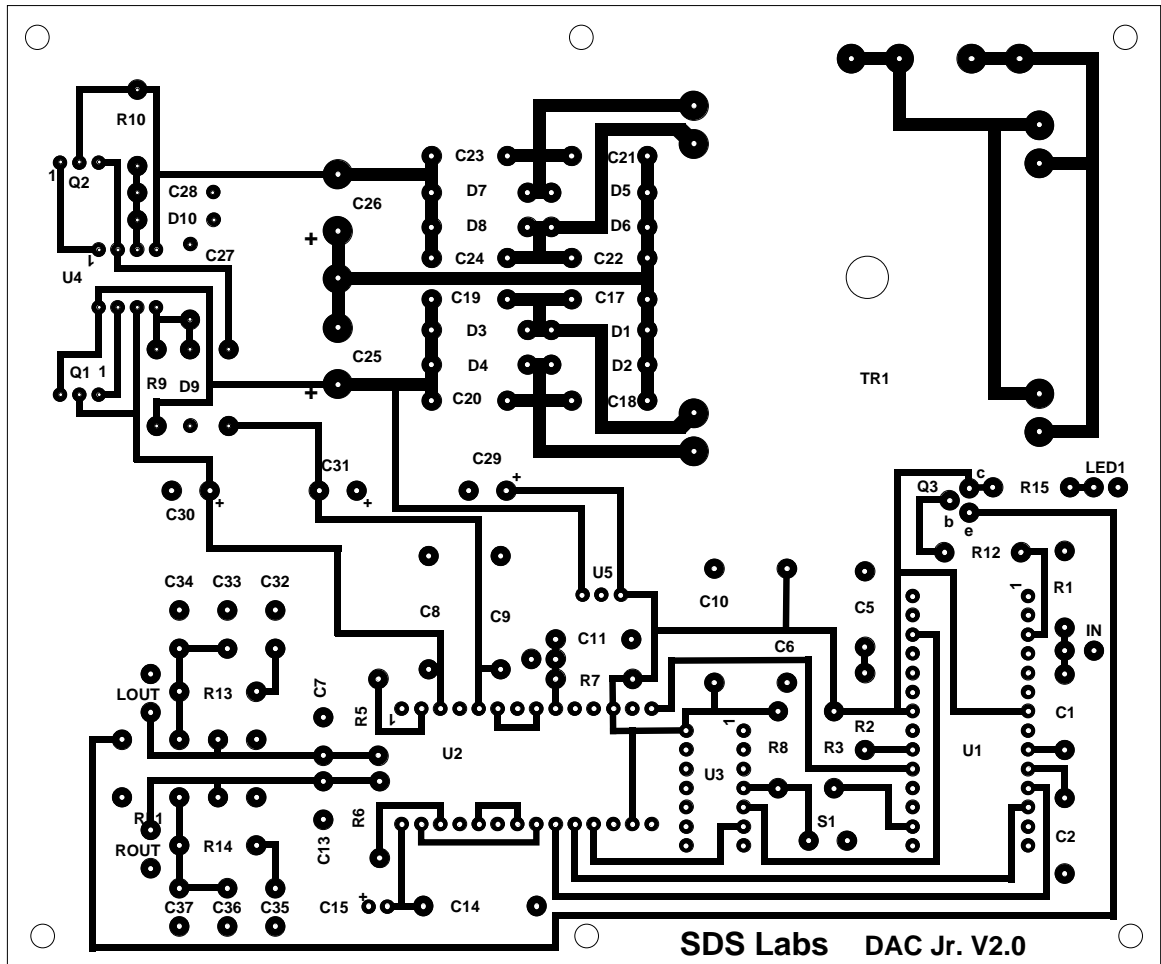

GROUND (COMPONENT) SIDE:

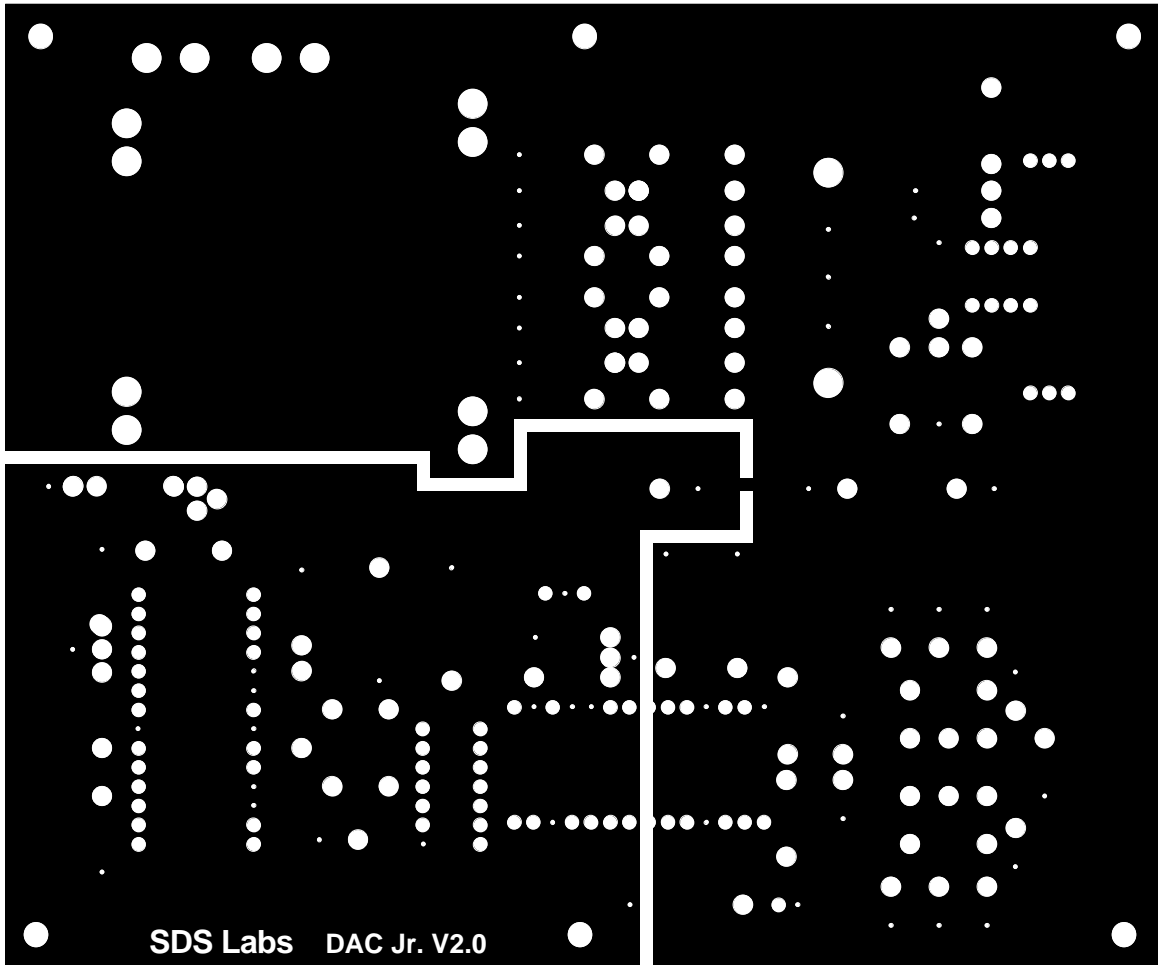

# COMPONENT OUTLINES:

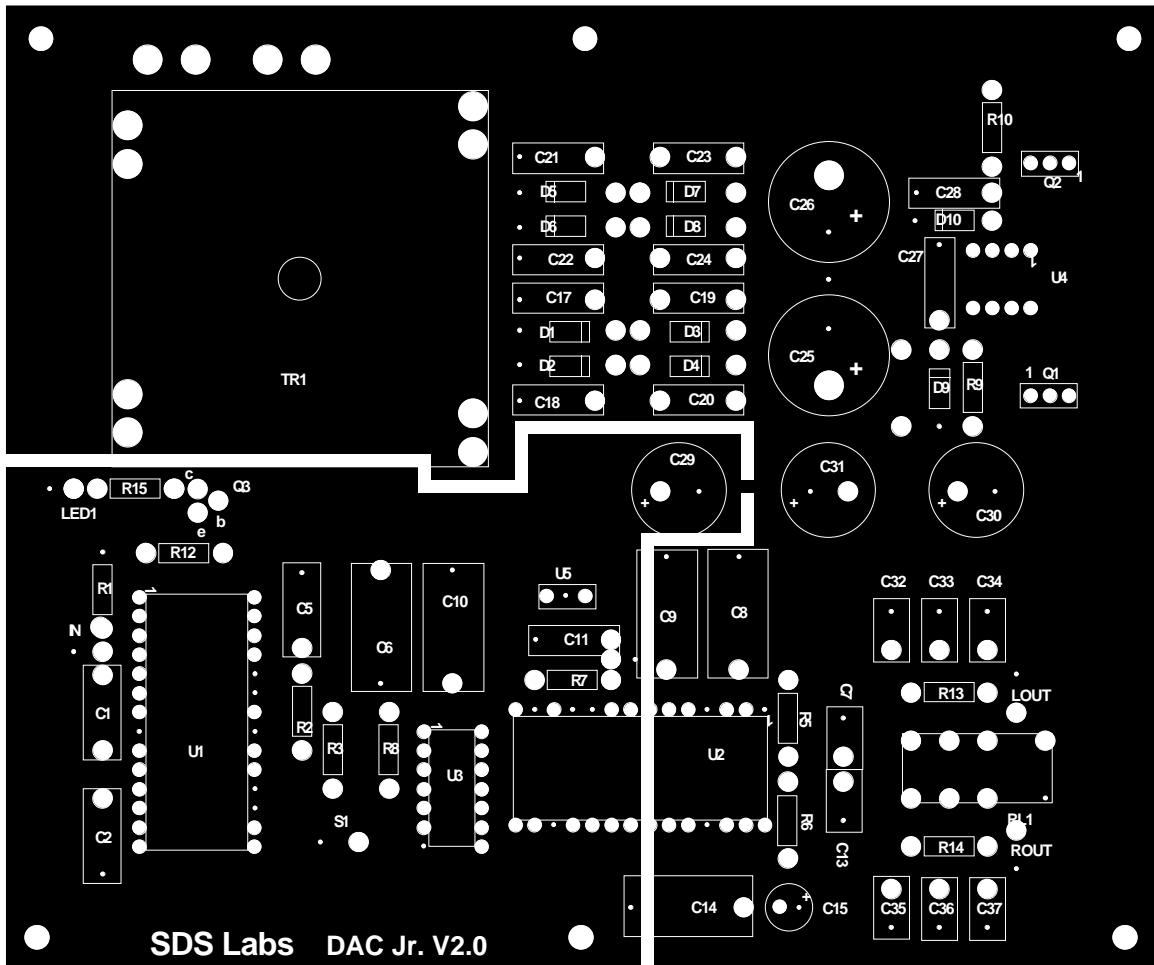

## PARTS LIST:

Part #	Description	Value	Part Number	Page	Manufacturer	Price	Num. @ price
TR1	Toroid Transformer	7.0 VA	807.072		Toriod Corp. Of Md	\$ 20.18	1
U1	Decoder Chip	CS8412-KP			Crystal Semiconductor	\$ 20.00	1
U2	DAC Chip	CS4328-KP			Crystal Semiconductor	\$ 50.00	1
U3	Exclusive OR Gate	CD74HCT86		p 68	Harris Semiconductor	\$ 0.47	1
U4	3 Terminal Regulator	7805	AN7805	p 70	Panasonic	\$ 0.59	1
U5	3 Terminal Regulator	7805	AN7805	p 70	Panasonic	\$ 0.59	1
U6	3 Terminal Regulator	7905	AN7905	p 70	Panasonic	\$ 0.59	1
U1'	Chip Socket (machined pin)	28 Pin	AE7228	p 62	Assman	\$ 1.73	1
U2'	Chip Socket (machined pin)	28 Pin	AE7228	p 62	Assman	\$ 1.73	1
U3'	Chip Socket (machined pin)	14 Pin	AE7214	p 62	Assman	\$ 0.86	1
C1	Film Capacitor	0.01 mF	E2103	p 183	Panasonic E-series	\$ 0.23	1
C2	Film Capacitor	0.01 mF	E2103	p 183	Panasonic E-series	\$ 0.23	1
C5	Film Capacitor	0.047 mF	E2473	p 183	Panasonic E-series	\$ 0.19	1
C6	Film Capacitor	1.0 mF	E1105	p 183	Panasonic E-series	\$ 0.64	1
C7	Film Capacitor	0.01 mF	P4513	p 179	Panasonic V-series	\$ 0.15	1
C8	Film Capacitor	1.0 mF	E1105	p 183	Panasonic E-series	\$ 0.64	1
C9	Film Capacitor	1.0 mF	E1105	p 183	Panasonic E-series	\$ 0.64	1
C10	Film Capacitor	1.0 mF	E1105	p 183	Panasonic E-series	\$ 0.64	1
C11	Film Capacitor	0.1 mF	E1104	p 183	Panasonic E-series	\$ 0.26	1
C13	Film Capacitor	0.01 mF	P4513	p 183	Panasonic V-series	\$ 0.15	1
C14	Film Capacitor	1.0 mF	E1105	p 183	Panasonic E-series	\$ 0.64	1
C15	Electrolytic Capacitor	330 mF	P6203	p 159	Panasonic SU-Series	\$ 0.17	1
C17	Film Capacitor	0.1 mF	E1104	p 183	Panasonic E-series	\$ 0.26	1
C18	Film Capacitor	0.1 mF	E1104	p 183	Panasonic E-series	\$ 0.26	1
C19	Film Capacitor	0.1 mF	E1104	p 183	Panasonic E-series	\$ 0.26	1
C20	Film Capacitor	0.1 mF	E1104	p 183	Panasonic E-series	\$ 0.26	1
C21	Film Capacitor	0.1 mF	E1104	p 183	Panasonic E-series	\$ 0.26	1
C22	Film Capacitor	0.1 mF	E1104	p 183	Panasonic E-series	\$ 0.26	1
C23	Film Capacitor	0.1 mF	E1104	p 183	Panasonic E-series	\$ 0.26	1
C24	Film Capacitor	0.1 mF	E1104	p 183	Panasonic E-series	\$ 0.26	1
C25	Electrolytic Capacitor	4700 mF	P6234	p 159	Panasonic SU-Series	\$ 1.62	1
C26	Electrolytic Capacitor	4700 mF	P6234	p 159	Panasonic SU-Series	\$ 1.62	1
C29	Electrolytic Capacitor	3300 mF	P6207	p 159	Panasonic SU-Series	\$ 0.81	1
C30	Electrolytic Capacitor	3300 mF	P6207	p 159	Panasonic SU-Series	\$ 0.81	1
C31	Electrolytic Capacitor	3300 mF	P6207	p 159	Panasonic SU-Series	\$ 0.81	1
C32	Film Capacitor	0.1 mF	P4525	p 179	Panasonic V-series	\$ 0.21	1
C33	Film Capacitor	0.033 mF	P4519	p 179	Panasonic V-series	\$ 0.18	1
C34	Film Capacitor	0.015 mF	P4515	p 179	Panasonic V-series	\$ 0.16	1
C35	Film Capacitor	0.1 mF	P4525	p 179	Panasonic V-series	\$ 0.21	1
C36	Film Capacitor	0.033 mF	P4519	p 179	Panasonic V-series	\$ 0.18	1
C37	Film Capacitor	0.015 mF	P4515	p 179	Panasonic V-series	\$ 0.16	1
D1	Fast Recovery Diode	1A 200 volt	1N4935GI	p 86	General Instrument	\$ 0.13	1
D2	Fast Recovery Diode	1A 200 volt	1N4935GI	p 86	General Instrument	\$ 0.13	1
D3	Fast Recovery Diode	1A 200 volt	1N4935GI	p 86	General Instrument	\$ 0.13	1
D4	Fast Recovery Diode	1A 200 volt	1N4935GI	p 86	General Instrument	\$ 0.13	1
D5	Fast Recovery Diode	1A 200 volt	1N4935GI	p 86	General Instrument	\$ 0.13	1
D6	Fast Recovery Diode	1A 200 volt	1N4935GI	p 86	General Instrument	\$ 0.13	1
D7	Fast Recovery Diode	1A 200 volt	1N4935GI	p 86	General Instrument	\$ 0.13	1
D8	Fast Recovery Diode	1A 200 volt	1N4935GI	p 86	General Instrument	\$ 0.13	1
R1	Metal Film Resistor (1/4 W)	75 Ohm	75.0X	p 199	Yageo	\$ 0.10	1
R2	Metal Film Resistor (1/4 W)	1 K Ohm	1.00KX	p 199	Yageo	\$ 0.10	1
R3	Metal Film Resistor (1/4 W)	10 K Ohm	10.0KX	p 199	Yageo	\$ 0.10	1
R5	Metal Film Resistor (1/4 W)	51 Ohm	51.1X	p 199	Yageo	\$ 0.10	1
R6	Metal Film Resistor (1/4 W)	51 Ohm	51.1X	p 199	Yageo	\$ 0.10	1
R7	Metal Film Resistor (1/4 W)	10 K Ohm	10.0KX	p 199	Yageo	\$ 0.10	1
R8	Metal Film Resistor (1/4 W)	10 K Ohm	10.0KX	p 199	Yageo	\$ 0.10	1
R12	Metal Film Resistor (1/4 W)	2 K Ohm	2.00KX	p 199	Yageo	\$ 0.10	1
R13	Metal Film Resistor (1/4 W)	150 Ohm	150X	p 199	Yageo	\$ 0.10	1
R14	Metal Film Resistor (1/4 W)	150 Ohm	150X	p 199	Yageo	\$ 0.10	1
R15	Metal Film Resistor (1/4 W)	150 Ohm	150X	p 199	Yageo	\$ 0.10	1
Q3	NPN Transistor	4401	2N4401PH	p 90	Phillips	\$ 0.31	1
RL1	DPDT Relay		Z770-ND	p 242	Omron	\$ 2.96	1
LED1	Blue LED		100CR-ND	p 114	Cree	\$ 2.80	1
						\$ 118.38	